

Qoltec[®]

USER MANUAL

MODEL: 53044

www.qoltec.pl



Please comply with all warnings and operating instructions described in this manual and read all the precautions before installing. Before operating this product, be sure to review all safety and operational instructions.



contents

1. Safety instruction	1
1-1. Transport and storage	1
1-2. Preparation	1
1-3. Installation	1
1-4. Operation	1
1-5. Standards applied	2
2. Install and Setting	2
2-1. Unpacking and inspection	2
2-2. Backplane view	3
2-3. Main Unit installation	4
2-4. Software installation	6
3. Using operation	6
3-1. Buttons functions	6
3-2. LED Indicator light and LCD display screen	6
3-3. Warning	8
3-4. Main unit operation	9
3-5. LCD Display abbreviation	11
3-6. LCD setting	12
3-7. Running mode/Status description	15
3-8. Error code	16
3-9. Warning instructions	17
4. Troubleshooting	17
5. Storage, maintenance and Warranty	18
5-1. Storage	18
5-2. Maintenance	18
5-3. Warranty	18
6. Product specification	19





1. Safety instruction

Please read the manual and safety instructions before installing and using this product.









1-1. Transport and storage

-  When you need to carry the UPS system, be sure to use the original packaging material to prevent and mitigate accidental shocks.
-  The place of UPS product is stored must be dry and well ventilated.



1-2. Preparation

-  When the UPS system is moved to the indoor warm environment directly from the cold environment, There may occur condensation. At this point be sure to wait until UPS system is completely dry. Therefore, after moving to the installation site, please wait at least 2 hours, so that UPS adapt to the environment before installation.
-  The UPS system must not be installed in the vicinity of the water or moist environment.
-  The UPS system must not be installed in the location of Sun straight or nearby heat source.
-  Never block or cover the ventilation holes of the UPS housing.

1-3. Installation

-  Never connect to the UPS's output. devices that can cause the UPS to be overloaded, such as high-power motor equipment.
-  Power lines and other lines in the wiring should avoid the places where will be stampede or Stumbled over.
-  Never block or cover the ventilation holes on the UPS housing. The location of the UPS installation must be well ventilated, confirm that there is sufficient ventilation around the UPS.
-  The UPS is equipped with a ground terminal ,for the installation is completed, for an external UPS battery box connected to constitute the electric potential grounding.
-  The UPS can only be installed by a professional qualified personel.
-  The construction system should provide a short circuit protection device.
-  The building system should be equipped with a lumped emergency switch so that when needed, shut down all UPS power supply in a timely manner.
-  Before connecting the UPS to the building system, firstly need to connect the UPS to the ground.
-  Installation and wiring must comply with local electricity laws and regulations.

1-4. Operation

-  Do not disconnect the grounding cable of the UPS or the grounding cable of the building system, Otherwise the protective grounding of the UPS system and the connected load will fail.
-  UPS is characterized by its own internal battery, so even if the UPS is not connected with any building wiring system, the output terminal block may still be charged.
-  If to completely disconnect the UPS system, firstly press the "OFF" key , and then disconnect the main power supply.

 Prevent any liquid or other foreign object go into the UPS system.

 The operation of this UPS system can be carried out by inexperienced persons.

1-5. Applied standard

* Safety	
IEC/EN 62040-1	
* EMI	
Transmit radiation	IEC/EN 62040-2 Category C3
Electromagnetic radiation	IEC/EN 62040-2 Category C3
*EMS	
ESD.....	IEC/EN 61000-4-2 Level 4
RS.....	IEC/EN 61000-4-3 Level 3
EFT.....	IEC/EN 61000-4-4 Level 4
SURGE.....	IEC/EN 61000-4-5 Level 4
CS.....	IEC/EN 61000-4-6 Level 3
Low frequency magnetic field.....	IEC/EN 61000-4-8 Level 4
Low frequency signa.....	IEC/EN 61000-2-2

2. Install and Setting

Model	53044
Type	Standard Machine

2-1. Unpacking and inspection

Please open the package and check whether the following items are complete.
The package contains the following items:

- UPS main unit
- User manual

Note: Before installing, please review the contents of the package, to confirm that there is no suspected damage or damage to the abnormal. If you have any damage or missing parts, please do not use this product, but should immediately notify the courier and your dealer. Please keep the original packaging materials for future use.

2-2. Backplane view

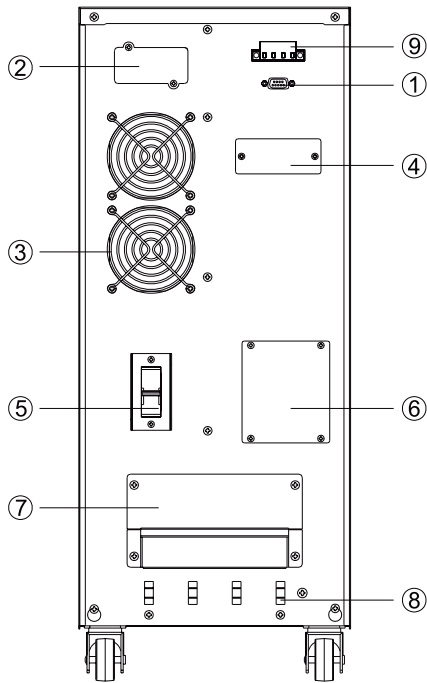

- ① Computer interface ② Smart slot ③ Fan ④ Parallel port cover plate (Combination card is optional)
 ⑤ Input protection switch ⑥ Maintain switch cover plate (Maintain switch is optional, Professional version has been installed)
 ⑦ Terminal block cover plate ⑧ Beam line frame ⑨ EPO (only for Professional version)

2-3. Main unit installation

Installation and wiring are subject to local electrical codes and laws and the following instructions are enforced by professional electricians:

- 1) Make sure that building distribution lines and circuit breakers are sufficient to support UPS capacity to avoid electric shock or fire accidents.
 Note: Do not use a wall outlet as a UPS input power (the rated current is less than the maximum input current of the UPS), otherwise the socket may be burned.
- 2) Before installing, turn off the power switch in the room.
- 3) All load equipment must firstly turn off the power, then connect the UPS system.
- 4) Prepare the wire according to the following table:

Model	Wiring specifications(AWG)			
	Input	Output	Battery	Ground Line
53044	8	8	8 (Long machine)	8

Note 1: It is recommended to use the above recommended or higher specifications of the wire to take into account the safety and efficiency. The standard machine does not need to have a battery cable.

Note 2: The color of the wire must be in accordance with the local electrical code.

- 5) Remove the terminal cover on the rear panel of the UPS. Then connect the ground wire according to the following schematic diagram: (When wiring please, firstly connect the ground wire, please keep the ground wire until final when the wiring is removed).

Single-phase terminal block

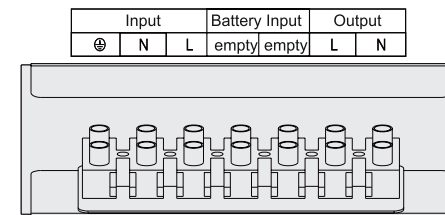

Model: 53044

Note 1: Make sure that all wires on the terminals are locked and fixed.

Note 2: Install the output circuit breaker between the output terminal and the load device, and make sure that the circuit breaker has a leakage protection function.

- 6) Replace the terminal cover back in place.

Warning: (For standard machine)

- ⊙ Before installation, pls make sure UPS not yet open, donot open UPS before installation.
- ⊙ Do not try to convert the standard UPS into long-running machine, In particular, the standard built-in battery can not be connected to external battery. This is because the battery specifications and voltage may be different, once connecting will bring electric shock or fire and other hazards.

Warning:

- ⊙ In the standard battery cabinet, a DC circuit breaker is provided to disconnect the battery cabinet and UPS. However, for the external battery, make sure that DC circuit breaker or other protective device with the same function is provided between the UPS and the external battery. If not, be careful when installing an external battery. When with circuit breaker, pls firstly disconnect the battery breaker, then install it.

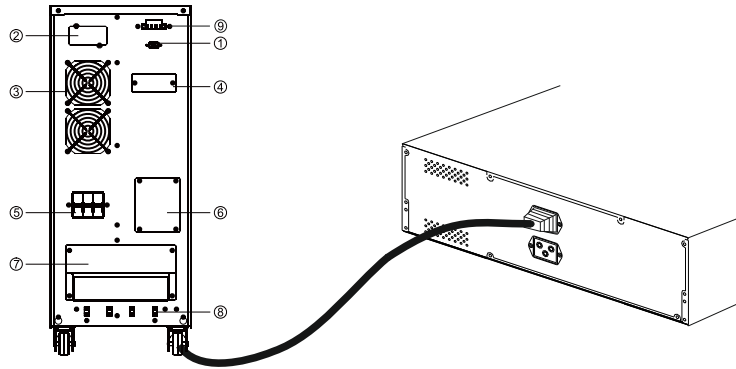

- ① Please pay attention to battery voltage marked on backboard. UPS may be damaged and unrepairable if wrong battery voltage connected. So please make sure battery voltage meet UPS standard.
- ② Please note to distinguish the anode and cathode marked on external battery terminal, to ensure they are correctly connected, or will causing UPS damage and unrepairable.
- ③ Please confirm if the ground wire is properly designed meeting required standard, especially the ampere rating, wire color, location, wire connection and conductivity.
- ④ Please make sure main supply input/output wiring are correctly connected as required, especially the ampere rating, wire color, location, wire connection and conductivity. Also check the fire wire and zero line are right connected, not inversely connected or short circuit connected.

2-4. Software installation:

To deliver a full-scale PC protection, please install the UPS monitoring software.

3. Operation

3-1. Buttons function

BUTTONS	FUNCTION
(ON/ENTER)	START: Press the button over 1 second to start UPS CONFIRMATION: Press to confirm in setup menu
(OFF/ESC)	Shutdown: Press this button for more than 1 second to turn off Cancel: In the setup menu, press this button to return to the previous menu
(TEST/UP)	TEST: Press the button over 1 second to test battery in mail supply mode UPWARD: Press to choose the next option in setup menu
(MUTE/DOWN)	MUTE: Press the button over 1 second to erase alarm (refer to 3-4-9 for details) DOWNWARD: Press to choose the upper option in setup menu
(TEST/UP+MUTE/DOWN)	Press the two buttons at the same time to access or quite the setup menu

CV CF mold refer to constant voltage and frequency mode.

3-2. LED indicator light and LCD display screen

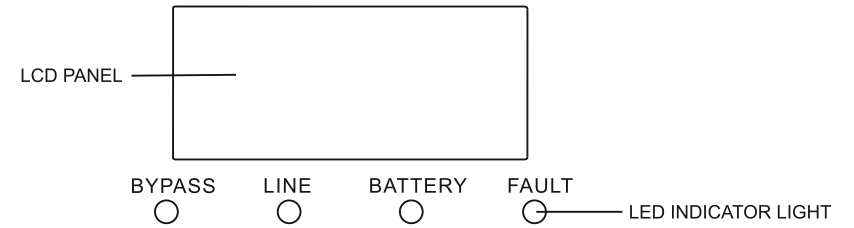

LED INDICATOR:

There're 4 LED indicator light designed on front panel, showing the UPS running status.

Status \ LED	Bypass	Line	Battery	Fault
UPS Restore	●	●	●	●
Bypass Mode	●	○	○	○
AC Mode	○	●	○	○
Battery Mode	○	○	●	○
CVCF Mode	○	●	○	○
Battery Test	●	●	●	○
Fault	○	○	○	●

Remarks: ● LED Light On ○ LED Light Off

LCD SCREEN:

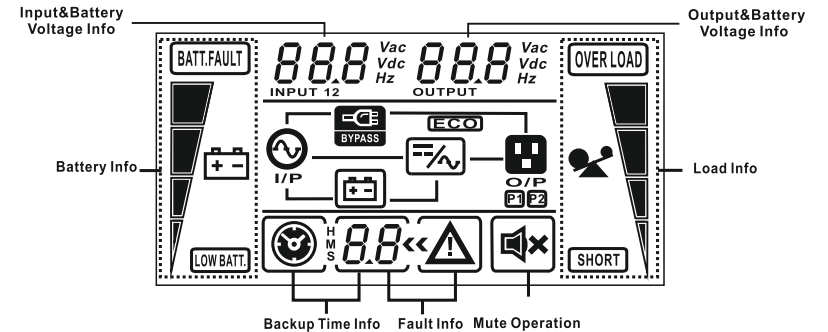

Display	Function
Backup Time Info	
	Backup Time Display H: hour M: minute S: second
Fault	
	Fault Happens
	Fault Code, code meaning refer to 3-9
Mute	
	Mute
Output & Battery Voltage Info	
	Output voltage, frequency or battery voltage Vac: Output voltage; Vdc: Battery Voltage; Hz: Frequency
Load Info	
	Segment display loading capacity 0-25%, 26-50%, 51-75%, 76-100%
	Overload
	Short circuit happens on load end or UPS output load
Other Running Info	
	Main supply connected
	Battery on work
	Bypass on work
	Inverter on work
	Output on work

Battery Info	
	Segment display battery capacity 0-25%, 26-50%, 51-75%, 76-100%
	Battery fault
	Low battery capacity
Input & Battery Voltage Info	
	Input Voltage or frequency or battery voltage Vac: Input voltage; Vdc: Battery voltage; Hz: Input frequency

3-3. Warning

INDICATING	ALARM	MUTE
UPS Status		
Bypass Mode	Rings every 2mins	OK
Battery Mode	Rings every 4 seconds	
Fault	Continued Ringing	
Warning		
Overload	Rings twice every second	NO
Low Battery Capacity	Ring every second	
Battery Unconnected		
Battery Overcharged		
EPO Start		
Fan Fault / Overheat		
Charger Fault		
Input Fuse Breaks		
Overload happens 3 times in 30mins		
Input Off Phase or Phase Loss		

Fault		
Bus Voltage Fail To Launch Through Software	Ringing all the time	OK
Bus Voltage Too High		
Bus Voltage Too Low		
Bus Voltage Unbalance		
Inverter Fail To Launch Through Software		
Inverter Voltage Too High		
Inverter Voltage Too Low		
Inverter Output Short Circuit		
Negative Work Fault		
Battery SCR Short Circuit		
Overheat		
CPU Communication Fail		
Charger Output Short Circuit		
Overload		

3-4. Main unit operation

1. Start Under Main Supply Mode

- 1) Confirm the system wiring and long-run machine battery cabinet voltage is right connected, then switch battery cabinet breaker to <ON> (this operation only adapts to long-run machine)
- 2) Switch main supply breaker to <ON>, then the inner power of UPS will auto-started, fan rotating, UPS entering initialize mode. With seconds later, UPS will run in bypass mode and output.

Remarks: When UPS is running under bypass mode and supply power for load through bypass, the load is not completely protected by UPS, only with the UPS started and running under main supply mode, the load can be completely protected. To better protect your facility, please start your UPS, and the detailed operating instruction is as low:

- 3) Press <ON> for over 1 second, with hearing a ringing, UPS will start under main supply mode.
- 4) If there's any abnormal main supply input after UPS started, the UPS will enter battery mode directly, to avoid interruption of power supply for load.

Remark: The UPS will shut down when battery run out of power in battery mode. Once main supply recovers, UPS will restart and switch to main supply mode.

2. Start Under Battery Mode

- 1) Please make sure the battery cabinet breaker is setting <ON>
- 2) Press and hold the <ON> button for more than 1 second to turn on the UPS, and you will hear the buzzer.
- 3) Seconds later, UPS will access to battery mode.

3. Connecting Devices

After UPS started, please connect your device with UPS

- 1) First start UPS, then start devices: LCD panel will show current load
- 2) Before connecting any inductive load like a printer, please calculate surge current, make sure UPS capacity is sufficient supporting all loads, cause such inductive loads have high power dissipation.
- 3) When UPS overloaded, the buzzer will ring twice a second. Now please reduce the load and keep an 80% load rate or below, to keep system running safe.
- 4) When UPS is overloaded, please erased some load and keep a total load under 80% load rate to avoid overload keeping system safe.
- 5) Under main supply mode, if overload happens over a certain time(refer to specification), UPS will switch to bypass mode. Once overload erased, UPS will switch back to main supply mode. If overload happens three times in half an hour, UPS will be locked under bypass mode, now need to press the start button restart UPS to access to main supply mode. If overload happen over a certain time under main supply mode (refer to specification), UPS will display fault.

4. Battery charging

- 1) When UPS is connected to the main supply, the battery will be charged automatically both under main supply mode or bypass mode, and battery will keep floating charge once filled.
- 2) It's suggested to charge battery for 10 hours before using or the backup time may be shorter than expected.
- 3) The charging current can be adjusted through LCD screen or software, the setting range for long-run machine is 0.5A-6A, a standard machine is 0.5A-2A, please set the right charging current according to our battery specification.

5. Battery Mode Operation

- 1) Under battery mode, the buzzer rings different according to battery remaining capacity: when battery remaining capacity over 25%, the buzzer rings 1 time/4 seconds; when capacity down to warning level, the buzzer rings 1 time/second indicating UPS battery is low to shut down automatically. In latter situation, user could erase some inessential load to extend backup time. If there's no any inessential load to be erased, please save data and shut down major load in quick, or user may face data lose or load off risk.

- 2) Under battery mode, user could press <Mute> to silence ringing noise.
- 3) Long-run machine backup time depends on external battery capacity.
- 4) Battery backup time varies according to different environment, temperature and different load.
- 5) When backup time sets at 16.5 hours (Default), after UPS supplying by battery with 16.5hs, UPS would shut down automatically to protect battery. The battery protection can be set to start or shut through LCD panel. (Operation refer to <3-7 LCD setting>)

6. Battery Self-checking

- 1) Under the main supply/CVCF mode, press <Test> button to enter battery self-checking status.
- 2) User can also use a battery monitor software to set battery self-checking execution.

7. Shutdown in mains mode

- 1) Press <OFF> button over 1 second, the buzzer would ring one time, then the inverter would shut down, UPS switch to bypass mode.

Remark 1: If UPS is set output through bypass, even UPS inverter shut down, the main supply would output through bypass directly.

Remark 2: If UPS is supplied by bypass when shut down, once main supply powers off, the load connected would risk of power off also.

- 2) Under bypass mode, the UPS output voltage remains on, only if the input breaker shuts down, the LED light offs second later, the UPS is completely shut down.

8. Shut down under battery mode

Press <OFF> button over 1 second under battery mode, the buzzer will ring once, the UPS will shut down all power input and output.

9. Mute buzzer

- 1) Press <Mute> button over 1 second will access to mute mode (refer to 3-3). Re-press <Mute> button to cancel.
- 2) Alarm ring cannot be muted.

10. Operation under alarm ringing

- 1) When <Fault> LED indicator light flicks and buzzer rings, it means fault happens with UPS running. User could find the fault code on LCD panel and solve problem according to chapter 4 detailed operation instruction.
- 2) The alarm cannot be shut down before fault erased in some case. (Please refer to 3-3 for more details)

11. Operation under fault mode

- 1) When <Fault> LED indicator light flicks and buzzer rings, it means a serious fault happens. User can find the fault code and solve problem according to chapter 4 detailed operation instruction.
- 2) When fault happens, please check the load, wiring, ventilation, main supply, battery carefully. Please don't try to restart UPS before problem solved. If user can't find our reason, please contact after sales or professional maintenance staff.
- 3) Any emergency, please break the main supply, external battery and output to avoid any extended risk

12. Battery Unit Number Alteration (apply to related machines)

- 1) This step can only operated by professional electricians.
- 2) Shut down UPS before operating.
- 3) Break the input breaker first and then break battery breaker.
- 4) Take off the cover and adjust the needle (CN1) to set battery unit number.
- 5) Please set battery unit number carefully and put back the cover.
- 6) Close battery breaker then close input breaker, UPS will access to bypass mode then.

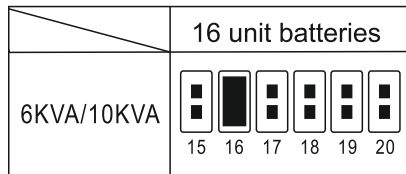

Remark: The black block refer to mini jumper

3-5. LCD Display abbreviation

Abb.	Display	Meaning
ENA	ENR	Enable
DIS	DIS	Disable
ATO	ATO	Auto
BAT	BAT	Battery
NCF	NCF	Normal Mode (not CVCF mode)
CF	CF	CVCF Mode
SUB	SUB	Subtract
ADD	ADD	Add
ON	ON	On
OFF	OFF	Off
FBD	Fbd	Not allowed
OPN	OPN	Allowed
RES	RES	Reserve

3-6. LCD Setting

Which of the following parameters can be set for the UPS

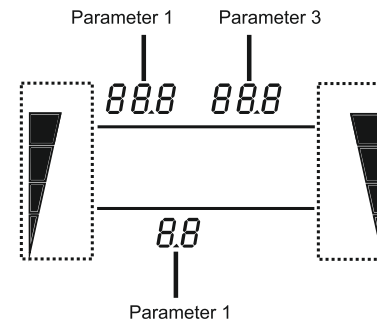

Parameter 1: Set item number, please set according to below diagram.

Parameter 2&3: Set value for each item

Remark: Please press "UP" or "DOWN" to select item or value

Parameter 1: Related Setting Items

Item #	Description	Bypass	AC	CVCF	Battery Test
01	Input Voltage	Y			
02	Output Frequency	Y			
03	Bypass Voltage Range	Y			
04	Bypass Frequency Range	Y			
05	Retain				
06	Retain				
07	Retain				
08	Bypass Mode Setting	Y	Y		
09	Battery Backup Time Setting	Y	Y		
10	Retain				
11	Retain				
12	Retain				
13	Battery Voltage Calibration	Y	Y	Y	Y
14	Charger voltage calibration (for single-phase models only)	Y	Y	Y	Y
15	Inverter Voltage Calibration		Y	Y	
16	Float Charging Voltage Calibration(unavailable for now)	Y	Y	Y	Y
17	Constant Voltage Calibration(unavailable for now)	Y	Y	Y	Y
18	Charging Current Setting	Y	Y	Y	Y
19	Battery Capacity & Battery Unit Number Setting	Y	Y	Y	Y
20	Discharging Time Calibration	Y	Y	Y	Y

Remark: Y means item can be set under related mode.

● 01 : Output voltage

Panel Display	Setup
	<p>Parameter 3: output voltage</p> <p>You can choose the following output voltage in parameter 3: 208: default output voltage is 208Vac 220: default output voltage is 220Vac 230: default output voltage is 230Vac 240: default output voltage is 240Vac</p>

● 02 : Output frequency

Panel Display	Setup
	<p>Parameter 2: output frequency Set up the output frequency. Parameter 2 has the following three options 50Hz: output frequency be set up to 50Hz. 60Hz: output frequency be set up to 60Hz. ATO: if you choose this option, the output frequency will depend on the most recent UPS normal electric frequency. If the electric frequency between 46~54Hz, the output frequency be set up to 50Hz; if the electric frequency between 56~64Hz, the output frequency be set up to 60Hz. ATO as the default value.</p> <p>Parameter 3: frequency mode Setup CVCF mode and non-CVCF mode output frequency. Parameter 3 has the following two options: CF: UPS be set up to CVCF mode If choose this option, the output frequency will be fixed at 50Hz or 60Hz depending the setup of parameter 2. Permissible input frequency rang is 46~64Hz. NCF: UPS be set up to normal mode(non-CVCF mode) If choose this option, the output frequency will be the same as the parameter 2, the input frequency between 46~54Hz, set up to 50Hz; or the input frequency between 56~64Hz, set up to 60Hz. If set up to 50Hz by parameter 2, but input frequency be not between 46~54Hz, UPS will turn into the battery mode; if set up to 60Hz by parameter 2, but input frequency be not between 56~64Hz, UPS will turn into battery mode.</p> <p>*If parameter 2 set up to be ATO, parameter 3 will display the current frequency.</p>

● 03 : Bypass voltage range

Panel Display	Setup
	<p>Parameter 2: Bypass mode allow the minimum voltage value. Setup range to 110~209V, default value is 110V. Parameter 3: Bypass mode allow the max. voltage value. Setup range to 231~276V, default value is 264V.</p>

● 04 : Bypass frequency range

Panel Display	Setup
	<p>Parameter 2: Bypass mode minimum allowable frequency. 50Hz system: setup the range from 46Hz to 49Hz. 60Hz system: setup the range from 56Hz to 59Hz. Default value is 46Hz/56Hz. Parameter 3: Bypass mode max. allowable frequency. 50Hz system: setup the range from 51Hz to 54Hz. 60Hz system: setup the range from 61Hz to 64Hz. Default value is 54Hz/64Hz.</p>

● 08: Bypass mode setup

Panel Display	Setup
	<p>Parameter 2: OPN: allow turn into bypass mode. If you choose this option, according to bypass function, UPS will start/stop setup to decide how to execute the bypass mode. FBD: do not allow into bypass mode. If you choose this option, UPS won't turn into bypass mode in any case. Parameter 3: this parameter is valid only for OPN. ENA: Bypass function start. While choose this option, bypass function will start the using. DIS: Bypass function stop. While choose this, it will allow UPS automatic turn into the bypass mode, but do not allow manual bypass mode. Manual bypass mode refers to the operation of turning UPS into the bypass mode by hand, for example while in AC mode, press <OFF> button to try turn UPS into bypass mode.</p>

● 09: Battery back-up time setup

Panel Display	Setup
	<p>Parameter 3: 000-999: set up max battery discharge time, range from 0mins to 999mins. When arrive at the set time, UPS will automatic close to protect battery. Default value is 990mins. DIS: stop the battery discharge protect function, back-up time depend on battery capacity.</p>

● 13: Battery voltage calibration

Panel Display	Setup
	<p>Parameter 2: choose <ADD> or <SUB> to adjusting battery voltage Parameter 3: voltage adjusting range is 0V~5.7V, default value is 0V.</p>

● 14: Charger voltage calibration

Panel Display	Setup
	<p>Parameter 2: choose <ADD> or <SUB> to adjusting charger voltage Parameter 3: voltage adjusting range is 0V~6V, default value is 0V. Note: only for single phase series</p>

● 15: Inverter voltage calibration

Panel Display	Setup
	<p>Parameter 2: choose <ADD> or <SUB> to adjusting inverter voltage Parameter 3: voltage adjusting range is 0V~6.4V, default value is 0V.</p>

● 18: Max. charging current setup

Panel Display	Setup
	Parameter 3: Max. charging current adjusting. Long-run machine's default value is 4A, setup range is 0.5A~6A; standard machine's default value is 1A, setup range is 0.5A~2A. Note: Any adjusting must comply with the battery specification requires. If input voltage lower than 200VAC, even set up to 6A, UPS still automatic reduce the charging current to 4A.

● 19: Battery capacity and battery group setup

Panel Display	Setup
	Parameter 2: according to battery capacity setup, such as 7AH, 9AH, 10AH, 12AH, 17AH, 26AH, 40AH, 65AH, 100AH, default value is 9AH. Parameter 3: setup the battery group value from 1 to 6. Default value is 1, this parameter is the standard of calculating the battery discharge time.

● 20: Discharging time calibration

Panel Display	Setup
	Parameter 3: this setting is calibrated the display discharge time by adjusting multiplier factor. Display time is equal to the original calculated discharge time multiplied by this setting value, default value is 1.0, range is 0.5~2.

3-7. Running mode / status description





















Running mode / state instructions		
AC mode	instruction	When input voltage in the allowable range, UPS can supply persistent AC power output. UPS in AC mode, also charging for battery.
	LCD display content	
CVCF mode	instruction	When input frequency between 46Hz~64Hz, UPS output frequency will stable at 50Hz or 60Hz depend on the setting. In this mode, UPS still charging for battery.
	LCD display content	

Battery mode	instruction	When input voltage be not in the allowable range or power off, UPS will provide output by battery, and sounding in every 4 seconds.
	LCD display content	
Bypass mode	instruction	When input voltage be in the allowable range and bypass function be enabled, UPS be not opened, UPS will turn into bypass mode, and sounding in every 2 minutes.
	LCD display content	
Battery self-inspection	instruction	When UPS in AC mode or CVCF mode, press "TEST" button for more than 1 second, UPS will turn into the battery self-inspection, and buzzer will sounding one time, the connect cable will blink between the icon I/P and inverter to prompt the user. This operation is in order to test the state of battery.
	LCD display content	
Error state	instruction	When the UPS fails, the failure information will be displayed on the LCD panel
	LCD display content	

3-8. Error Code









Fault event	Fault code	Image	Fault event	Fault code	Image
Bus soft start fail	01	NO	Negative work breakdown	1A	NO
Bus voltage too high	02	NO	Battery SCR short circuit	21	NO
Bus voltage too low	03	NO	Inverter relay short circuit	24	NO
Bus voltage unbalance	04	NO	Charger output short circuit	2A	NO
inverter soft start fail	11	NO	Overheat	41	NO
Inverter voltage too high	12	NO	CPU communication fault	42	NO
Inverter voltage too low	13	NO	Overload	43	OVERLOAD
Inverter output short circuit	14	SHORT			

3-9. Warning instructions

Warning content	Mark (flicker)	Alarm sound	Alarm code
Battery unconnected	 	One sound per second	01
Three phase input missed or lacked		One sound per second	02
Three Phase Input Dislocation		One sound per second	04
Battery overcharge	 	One sound per second	07
Battery voltage too low	 	One sound per second	08
Overload	 	Two sounds per second	09
EPO start	 	One sound per second	0b
Fan fault / overheat	 	One sound per second	0d
Charger fault	 	One sound per second	0E
Three times overload in 30 minutes		One sound per second	33
Three phase input extreme unbalance		One sound per second	3C
I/P fuse disconnect	 	One sound per second	

4. Troubleshooting

When UPS system be abnormal working, please try to solve problems according to the following.

Question situation	Possible reason	Solve ways
Main power be normal, but without any flicker indicator light, no alarm voice	AC input power get loosed, bad connect	Check whether the input cable be loosed
LCD screen display the mark  and error code be flickering, buzzer be one sound per second	EPO function had been started	Please shut off the EPO wire, to stop the EPO function
LCD screen display the mark  and  be flickering, buzzer be one sound per second	Extend battery connect way be wrong	Check whether all of the battery connect ways be correct
LCD screen display the mark  and  be flickering, buzzer be two sounds per second	UPS overload	Remove the parts of ultra-rated load
	UPS overload, and UPS be currently using the bypass way to supply power for equipment by AC directly.	Remove the parts of ultra-rated load
	Many times overload in short time, UPS currently be locked to bypass mode, supply power by AC directly	Remove the parts of ultra-rated load, and restart UPS
Fault code show 43 and the mark  be flickering, buzzer rings all the time	UPS overload time be too long to enter the fault status, and shutdown automatically	Remove the parts of ultra-rated load, and restart UPS
Fault code show 14 and the mark  be flickering, and buzzer rings all the time	UPS shutdown automatically, the output be in short circuit	Check the output wiring, confirm whether the equipment be in short circuit
LCD screen display the other fault codes, and buzzer rings all the time	UPS inner part's fault	Please contact with your distributor
Battery backup time be shorter than the specification	Maybe battery not fully charged	Please charging at least 7 hours, then check the battery power. If still low, please contact with your distributor.
	Battery's fault	Please contact your distributor, and change
LCD screen display the mark  and  be flickering, buzzer be one	Fan be stuck or unable to rotate; or UPS overheat	Check the fan and contact with your distributor











5. Storage, maintenance and warranty

5-1. Storage

Before storage this product, at first please charging 7 hours. And it should be stored by an upright way in a dry place. During the storage, please carry out the charging maintenance as the following sheet.

Storage temperature	Charging interval	Charging time
-25°C - 40°C	In every three months	1 hour to 2 hours
40°C - 45°C	In every two months	1 hour to 2 hours

5-2. Maintenance

-  UPS system using the dangerous voltage, only qualified maintainer able to repair.
-  Electrocutation can occur. Even shut off the main power, the UPS system inner module still connect with battery
-  Do any service or maintain, shut off the battery at first, and confirm that there is no dangerous voltage in the both ends of bus capacitor.
-  Only accendant who be fully familiar with the battery and equipped with protective measures can do or supervise the replacement of battery. Unauthorized person must stay far away from it.
-  Electrocutation can occur. Battery wiring and AC input be non-isolated. Maybe exist dangerous voltage between battery terminal and grounding.
-  Battery maybe cause the electric shock, occur the short circuit big current. Before maintain, please take off watch, ring and other metal materials, and use tools with insulated handle and shank during the maintenance.
-  When replace battery, please install the same quantity and specification.
-  Do not throw battery into fire, or maybe occur an explosion. Obsolete battery should be disposed according to the local regulation.
-  Do not disassemble and damage the battery, if the battery's electrolyte leak, will make hurt for skin and eyes, even maybe bring toxicity.
-  Could only change the fuse with same type and amperage, avoid fire.
-  Laypeople cannot disassemble the UPS system

5-3. Warranty

Company promise: since the date of purchase, provide three years warranty service

- Depend on distributor's effectively certify for warranty.
- Depend on machine's production sequence number for warranty.
- During warranty period, transport cost shall be borne by user. If the machine fails, please contact with the nearest service branch and distributor

As this product user, you can have the following service:

- Three years National Joint Warranty

The following situations be not covered under warranty:

- * Beyond the warranty time;
- * Sequence number be changed and lost;
- * Capacity be in normal drop or outer damage for storage battery;
- * The fault and damage by transportation, movement, careless after the purchase;
- * The damage caused by natural and man-made disaster of force majeure
- * The failure caused by power supply condition or site environment that be not according to the UPS electrical specification.

6. Product Specification

MODEL		53044
CAPACITY		10KVA/8000W
INPUT		
Voltage range	Min. transfer	With 50% load, 110VAC \pm 3%; With 100% load, 176VAC \pm 3%
	Min. reply	Minimum transfer voltage \pm 3%
	Max. transfer	300VAC \pm 3%
	Max. reply	Maximum transfer voltage – 10V
Frequency range		46Hz – 54Hz @ 50Hz system; 56Hz – 64Hz @ 60Hz system
Phase		Single phase grounding mode
Power factor		With 100% load \geq 0.99
OUTPUT		
Output voltage		208 / 220 / 230 / 240VAC
AC voltage range		\pm 1%
Frequency range		46Hz – 54Hz @ 50Hz system; 56Hz – 64Hz @ 60Hz system
Frequency range (battery mode)		50Hz \pm 0.1Hz or 60Hz \pm 0.1Hz
Over-load	AC \leftrightarrow battery	100%-110%: 10mins; 110%-130%: 1min; >130%: 1s
	Inverter \leftrightarrow bypass	100%-110%: 30s; 110%-130%: 10s; >130%: 1s
Current peak ratio		3:1 (max value)
harmonic distortion		\leq 3% THD linear load; \leq 6% THD non-linear load
Transfer time	AC \leftrightarrow battery	0ms
	Inverter \leftrightarrow bypass	4ms (under the standard condition)
Efficiency		
AC mode		> 90%
Battery mode		> 89%
BATTERY		
Standard mode	Model / quantity	12V / 7AH OR 12V / 9AH x 16
	Charging time	90% capacity after 9 hours
	Charging current	Preinstall: 1A \pm 10%; maximum value: 2A
	Charging voltage	218.4VDC \pm 1%
Long run mode	Model	Depend on the usage
	quantity	16 – 20 (can be adjusted, in kind)
	Charging current	Preinstall: 4A \pm 10%; maximum value: 6A \pm 10%
	Charging voltage	N x 13.65VDC \pm 1% (N is the battery's quantity)
APPEARANCE		
Standard mode	Size	500*240*616 (mm)
	N.W.	63
Long run mode	Size	500*240*460 (mm)
	N.W.	22
ENVIRONMENTAL CONDITION		
Operation temperature		0 - 40°C (Battery life will be shortened in an environment larger than 25°C)
Operation humidity		< 95% RH and without condensation situation
Operation altitude		< 1000 meter
Noise		< 55dB @ 1meter
MANAGEMENT		
Smart RS232 or USB(optional)		Support Windows®2000/2003/XP/Vista/2008, Windows®7/8, Linux, Unix and MAC

* At CVCF mode, the electricity will be reduced to 60%; when the output voltage be set up to 208VAC, the electricity will be reduced to 80%.

** If UPS be installed, and for an environment of more than above 1000meters altitude, the output power should be reduced by 1% per 100meters in computation.

***The specification be subject to change without notice, please forgive.

Producer: nTec
Chorzowska Str. 44B
44-100 Gliwice
Poland
www.qoltec.com

